



TEST CODE **02107010**

FORM TP 2006176

MAY/JUNE 2006

C A R I B B E A N E X A M I N A T I O N S C O U N C I L

ADVANCED PROFICIENCY EXAMINATION

BIOLOGY

UNIT 1 – PAPER 01

1 $\frac{3}{4}$ hours

Candidates are advised to use the first 15 minutes for reading through this paper carefully.

READ THE FOLLOWING INSTRUCTIONS CAREFULLY.

1. Candidates must attempt ALL questions in this paper.
2. Answers are to be written in the spaces provided in this answer booklet.
3. EACH question is worth 10 marks.
4. The use of silent non-programmable calculators is allowed.

1. (a) Figure 1 below shows three diagrams of water molecules in the solid, liquid and gaseous state.

Indicate the state of the water molecules in EACH of the diagrams (i), (ii) and (iii).

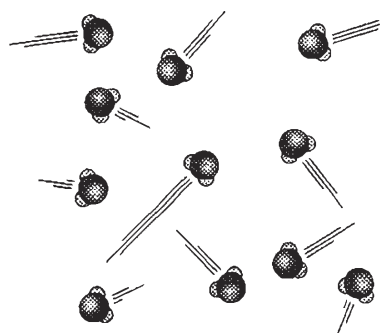

(i) _____

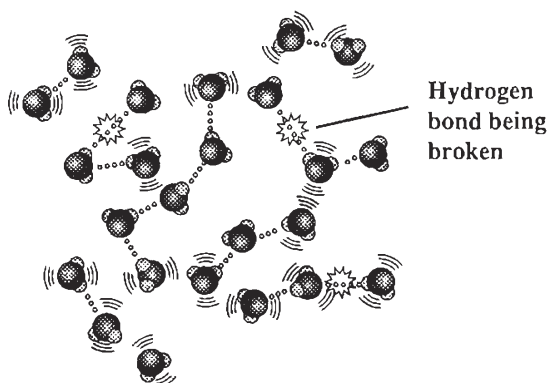

(ii) _____

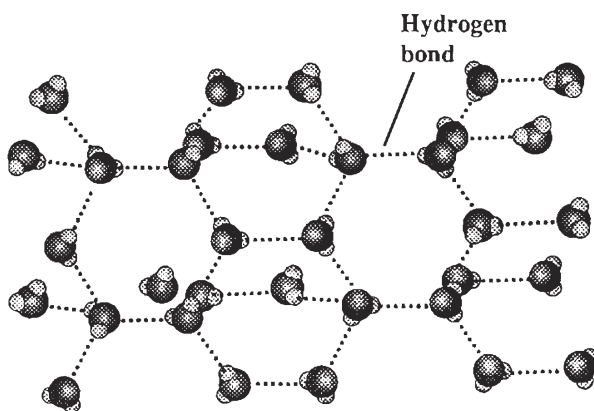

(iii) _____

Figure 1. Water molecules in three states

[3 marks]

- (b) Ice floats on water.

Explain why this property of water is important.

[1 mark]

- (c) In Figure 2 below, an insect (a pondskater) uses the properties of water to skate on the surface.

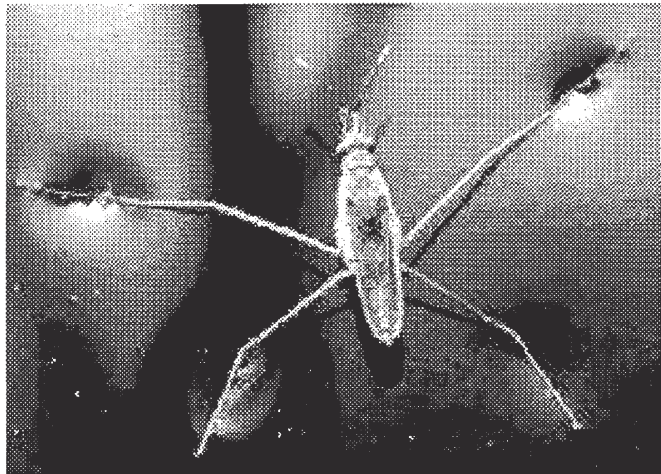

Figure 2. A pondskater skates across the surface of water

Name TWO properties of water used by the insect **and** describe how these properties operate.

Property 1: _____

_____ [1 mark]

Property 2: _____

_____ [1 mark]

- (d) A saccharide molecule is shown in Figure 3 below.

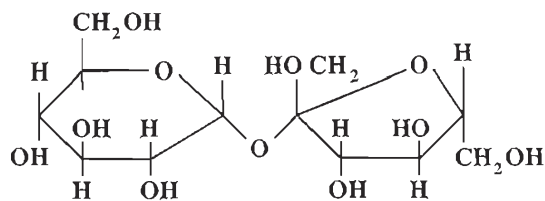

Figure 3. Molecule A

- (i) Name Molecule A in Figure 3 and state what type of saccharide it is.

_____ [1 mark]

- (ii) Describe the MAIN function of Molecule A in plants.

_____ [1 mark]

- (e) Name the MAJOR structural polymer that is found in plants that consist of glucose units.

_____ [1 mark]

- (f) Explain why the polymer named in (e) is NOT soluble in water even though its component glucose units are very soluble in water.

_____ [1 mark]

Total 10 marks

2. Figure 4 (i) and (ii) show a two-inch deep section of a cucumber, with a longitudinal strip cut from the side. The strip has a tough outer covering of cuticularized epidermis, while the inner part is composed of cortical parenchyma cells. As soon as the strip is cut out of the cucumber, it “bends backwards”, as shown in Figure 4 (iii).

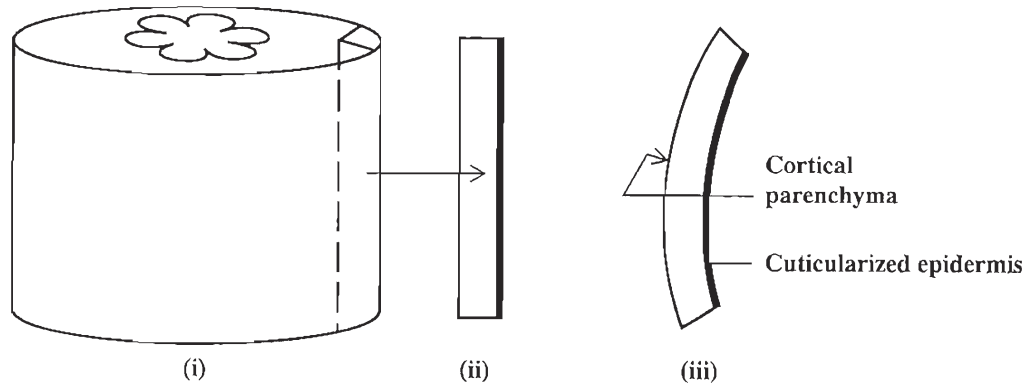

Figure 4. Sections cut from a cucumber

Five strips are cut, placed in petri dishes and covered with sucrose solutions of varying concentrations for 30 minutes. The degree of curvature in relation to the sucrose concentration is shown in Table 1.

TABLE 1: CURVATURE OF STRIPS IN RELATION TO SUCROSE CONCENTRATION

Molar concentration of sucrose solution	0.1 m	0.2 m	0.3 m	0.4 m	0.5 m
Shape of cucumber strips after 30 mins immersion					

(a) Define the following in terms of water potentials:

(i) Osmosis

[1 mark]

(ii) Isotonic

[1 mark]

(b) Use Table 1 to determine which solution is isotonic with the cucumber cells, and give ONE reason for your answer.

[1 mark]

(c) State precisely what happens to the cortical cells in the

(i) 0.1 m sucrose solution

[2 marks]

(ii) 0.5 m sucrose solution.

[2 marks]

GO ON TO THE NEXT PAGE

- (d) Give ONE reason why the strip shown in Figure 4 (iii) curves “backwards” immediately after it is released.

[1 mark]

- (e) The outer regions of the stems of herbaceous plants possess a cortex and an epidermis. Explain how these structures enable the stem to stay erect.

[2 marks]

Total 10 marks

3. Figure 5 shows a student's drawing of a plant cell as seen from an Electron Micrograph.

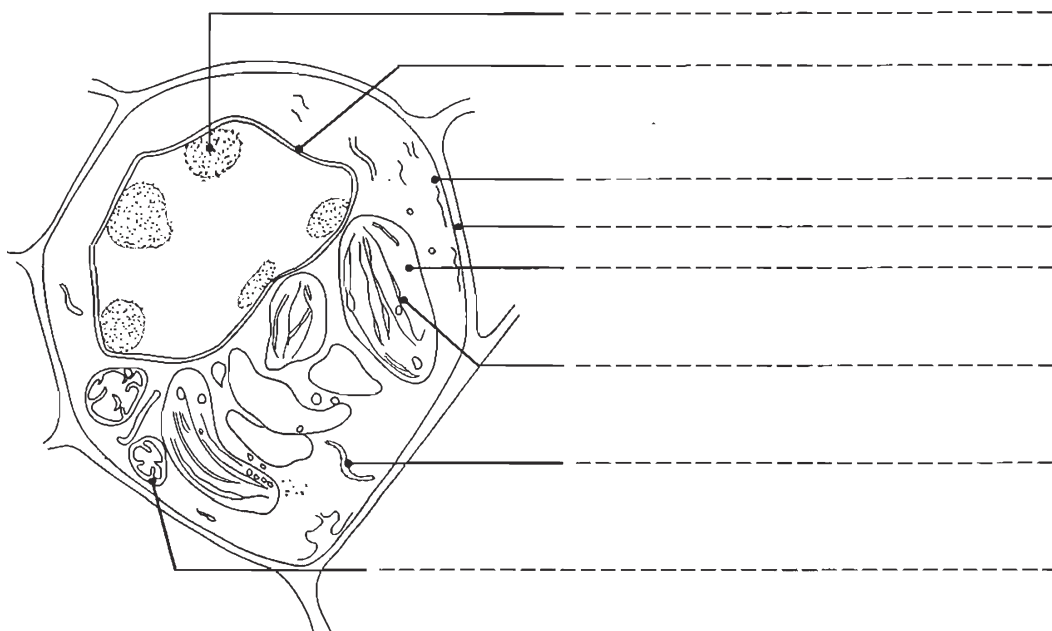

Figure 5. Student's drawing of a plant cell as seen from electron micrograph

- (a) Complete the labelling of the student's drawing by writing in the spaces provided, the name of EACH part of the cell identified by the lines. [4 marks]

- (b) The electron micrograph in Figure 6 below shows a membrane system in the cell.

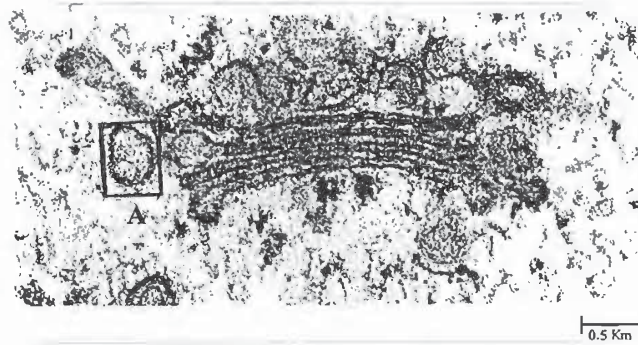

Figure 6. An electron micrograph of a membrane system

- (i) Identify the membrane system shown in Figure 6.

_____ [1 mark]

- (ii) Describe the function of the membrane system identified in (i).

_____ [1 mark]

- (iii) Determine the width of vesicle A within the box in Figure 6.

_____ [1 mark]

- (c) Figure 7 below shows an electron micrograph of an organelle found in plant and animal cells.

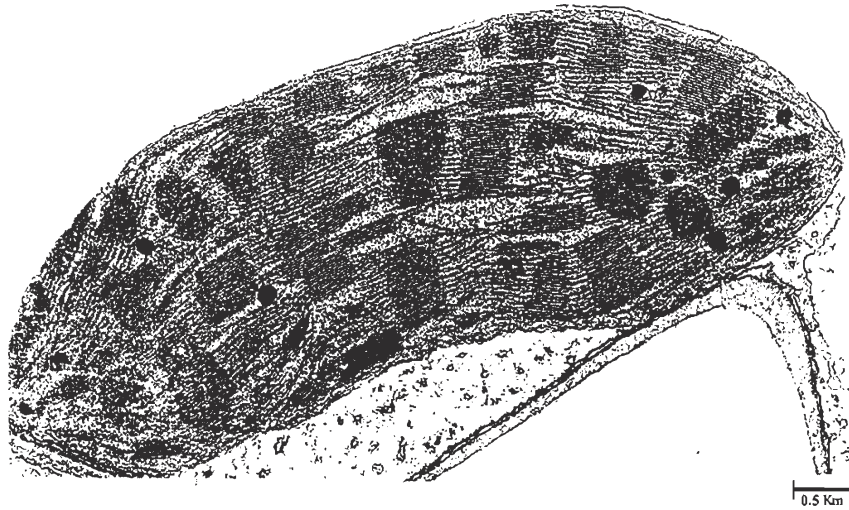

Figure 7. An electron micrograph of an organelle in the cell

Describe TWO functions of the organelle shown in Figure 7 above.

[2 marks]

- (d) Name TWO organelles or cellular structures present in animal cells but absent from plant cells.

[1 mark]

Total 10 marks

4. In Figure 8 below there are five micrographs, (i) – (v), of the stages of mitosis.

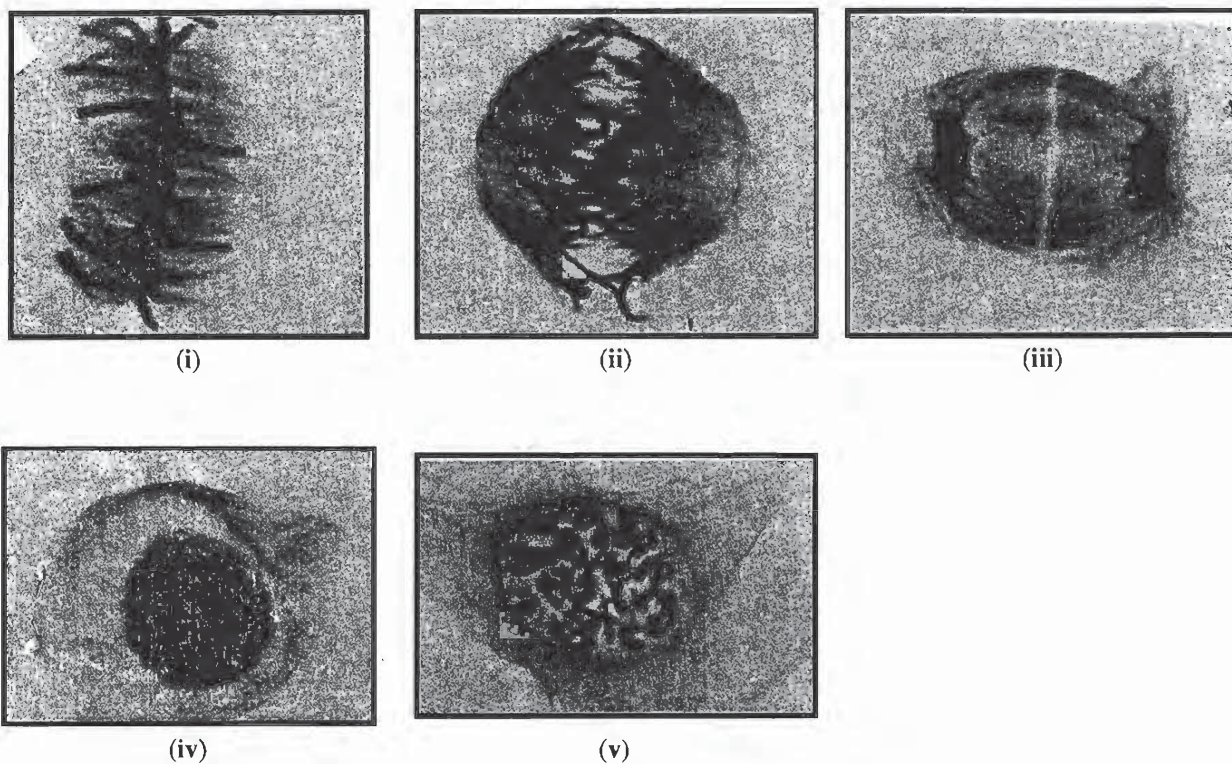

Figure 8. Stages of mitosis

(a) Name EACH of the stages of mitosis shown in Figure 8 above.

(i) _____ (iv) _____

(ii) _____ (v) _____

(iii) _____

[3 marks]

(b) A potato plant has 24 pairs of chromosomes in its somatic cells.

Determine the number of chromatids in its somatic cells at

(i) **Prophase** of mitosis _____

(ii) **Anaphase** of mitosis _____

[2 marks]

- (c) A chemical disrupts the formation of spindle fibres when it is added to cells that are undergoing mitosis.

Predict the effect the chemical would have on the process of mitosis.

[2 marks]

- (d) Distinguish between the terms '**chromatid**' and '**chromatin**'.

[2 marks]

- (e) Name TWO processes occurring in all living organisms in which mitosis plays an important role.

[1 mark]

Total 10 marks

5. Figure 9 below is a diagram of part of the human reproductive system during gestation.

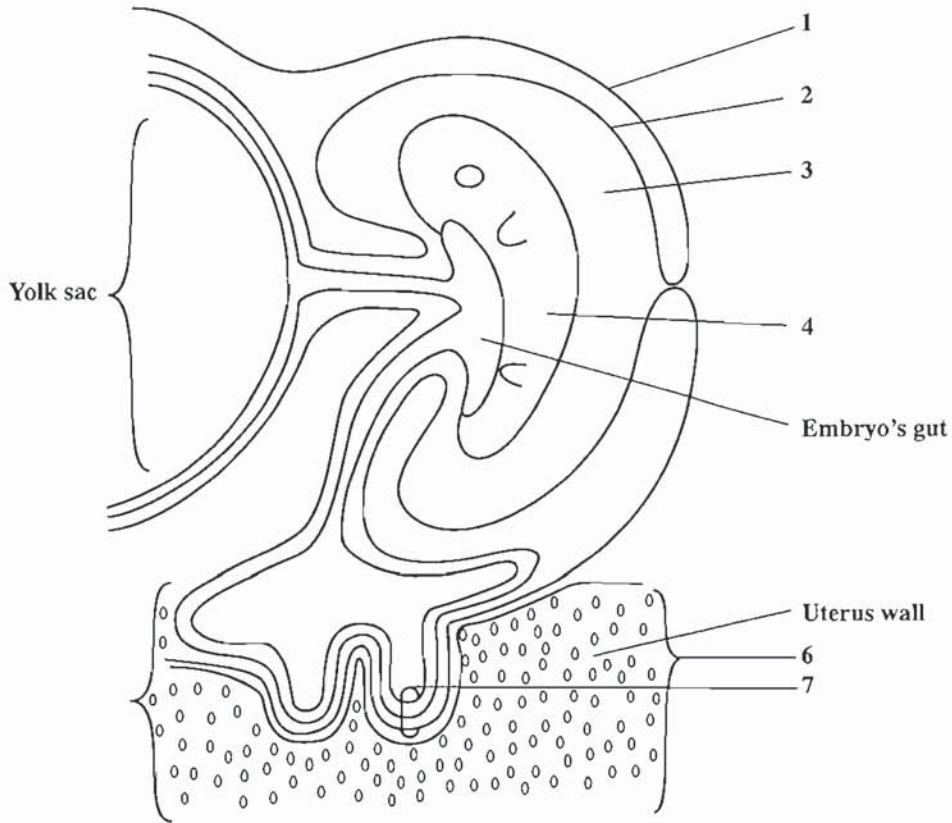

Figure 9. Reproductive system during gestation

(a) Identify the structures labelled 1 to 4 in Figure 9 above.

1 _____ 2 _____
3 _____ 4 _____

[2 marks]

(b) State TWO functions of the **amnion**.

[2 marks]

- (c) In Figure 9, in label 7, three membranes are closely associated.

Name these THREE membranes.

[1 mark]

- (d) State how the structures at 6 and 7 develop further as gestation progresses.

[2 marks]

- (e) List FOUR functions of the placenta.

[2 marks]

- (f) "The umbilical artery carries oxygenated blood from the embryo's heart to the placenta".

Is this statement true or false? If it is true, write "TRUE" below. If it is false, write the corrected statement below.

[1 mark]

Total 10 marks

6. Figure 10 shows various aspects of the human uterine and ovarian cycles.

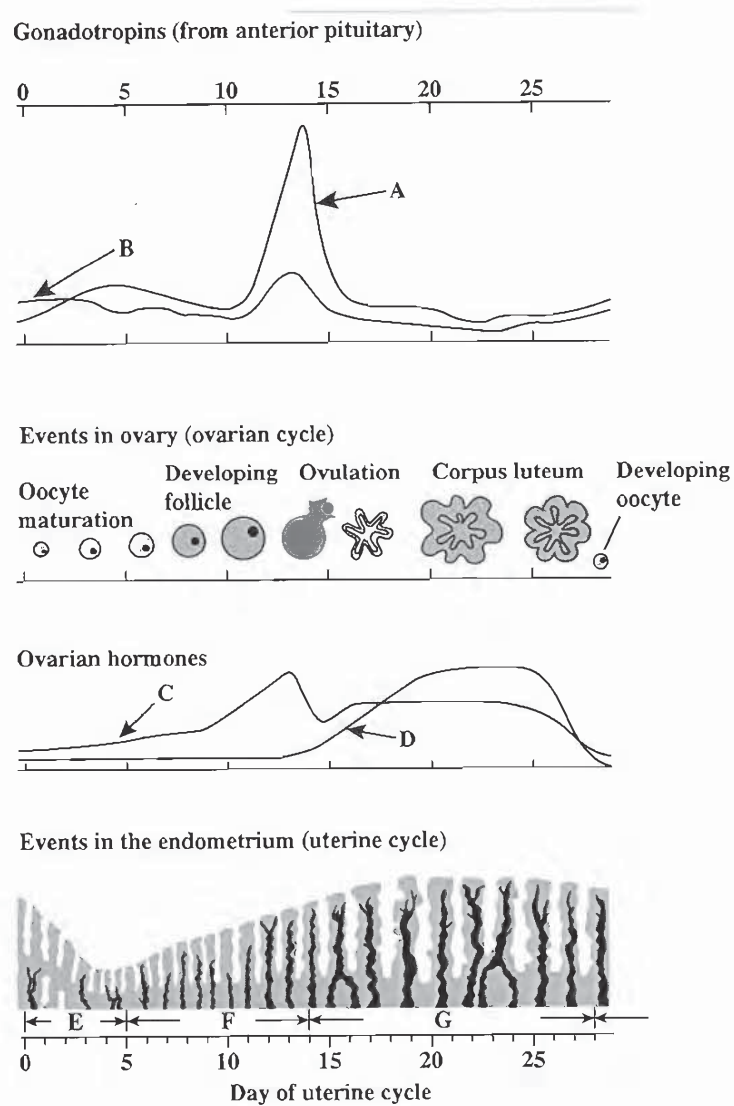

Figure 10. The human uterine and ovarian cycles

(a) Name the hormones A to D represented on the graphs in Figure 10.

Hormone A: _____

Hormone B: _____

Hormone C: _____

Hormone D: _____

[2 marks]

GO ON TO THE NEXT PAGE

- (b) Describe the events occurring in the endometrium of the uterus at E, F and G in Figure 10.

Events at E: _____

Events at F: _____

Events at G: _____

[3 marks]

- (c) The birth-control pill RU-486 contains a progesterone-like molecule. Suggest how this pill prevents conception.

[2 marks]

- (d) In the process of gamete production, state

(i) how many sperm are produced from EACH diploid sex cell (primary spermatocyte)

[1 mark]

(ii) the number of secondary oocytes produced from EACH sex cell (primary oocyte)

[1 mark]

(iii) the name of the other **type** of cell that is produced ALONG WITH the secondary oocyte.

[1 mark]

Total 10 marks

7. (a) State TWO items of information which can be obtained by performing a Chi-squared (χ^2) test.

[2 marks]

- (b) (i) State the phenotypic ratio obtained from an F_1 dihybrid cross.

[1 mark]

- (ii) When using a table of χ^2 values, state and explain why 3 would be chosen for the degrees of freedom from the F_2 progeny.

[1 mark]

- (c) In summer squash, the fruit can be disc-shaped or spherical, and white or yellow in colour. The dihybrid genotype Ww Dd produces a white, disc-shaped phenotype. The school agricultural project harvested a field of squash and students counted 3220 in all, of which 1820 were white discs, 610 white spheres, 590 yellow discs and 200 yellow spheres. The students performed a chi-squared test on the results.

- (i) Complete Table 2 to determine the value of χ^2 , to TWO decimal places.

TABLE 2: TO DETERMINE CHI-SQUARED VALUE

Phenotype	Observed results (O)	Expected results (E)	(O - E)	(O - E) ²	$\left(\frac{(O - E)^2}{E}\right)$
White disc	1 820	<input type="text"/>	8.75	76.56	<input type="text"/>
White sphere	610	603.75	6.25	<input type="text"/>	<input type="text"/>
Yellow disc	590	603.75	<input type="text"/>	189.06	<input type="text"/>
Yellow sphere	200	201.25	-1.25	<input type="text"/>	<input type="text"/>

[4 marks]

- (ii) What is the sum of $\left(\frac{(O - E)^2}{E}\right)$? _____ [1 mark]
- (iii) Refer to Table 3 below to find the value of χ^2 at 5% probability.

TABLE 3: TABLE OF χ^2 VALUES

Degrees of Freedom	Number of Classes	χ^2 values						
1	2	0.46	1.64	2.71	3.84	6.64	10.83	
2	3	1.39	3.22	4.61	5.99	9.21	13.82	
3	4	2.37	4.64	6.25	7.82	11.34	16.27	
4	5	3.36	5.99	7.78	9.49	13.28	18.47	
Probability (p) that chance alone could produce the deviation		0.50 (50%)	0.20 (20%)	0.10 (10%)	0.05 (5%)	0.01 (1%)	0.001 (0.1%)	

Value of χ^2 at 5% probability: _____ [1 mark]

Total 10 marks

8. (a) State clearly what is meant by the term 'mutation'.

[1 mark]

- (b) State TWO conditions which cause mutations.

[1 mark]

- (c) When chromosomes come together during meiotic interphase, exchange of chromosomal material may occur. Figure 11 below shows two homologous chromosomes (each composed of two chromatids) with chiasmata.

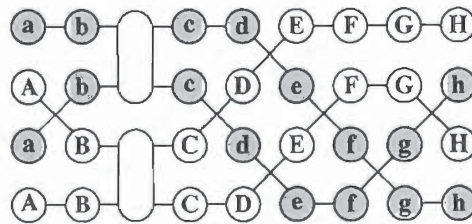

Figure 11. A pair of homologous chromosomes with chiasmata

- (i) In Figure 12 below identify the letters in the four separate chromatids, after the above interaction, with the four separate centromeres. Use the upper-and lower-case letters to accurately indicate the arrangement of the alleles of the genes on the pairs of chromosomes. Assume a reconnection to the opposing homologue or chromatid at each chiasma.

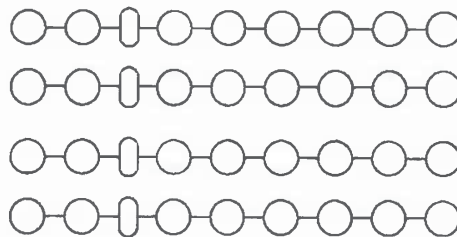

Figure 12. Incomplete diagram

[2 marks]

- (ii) Name the type of rearrangement that has occurred when a chromatid results with the following combination of alleles:

A B C D H G F E I J K L

[1 mark]

- (d) Figure 13 shows the effect of maternal age on the incidence of Down's syndrome.

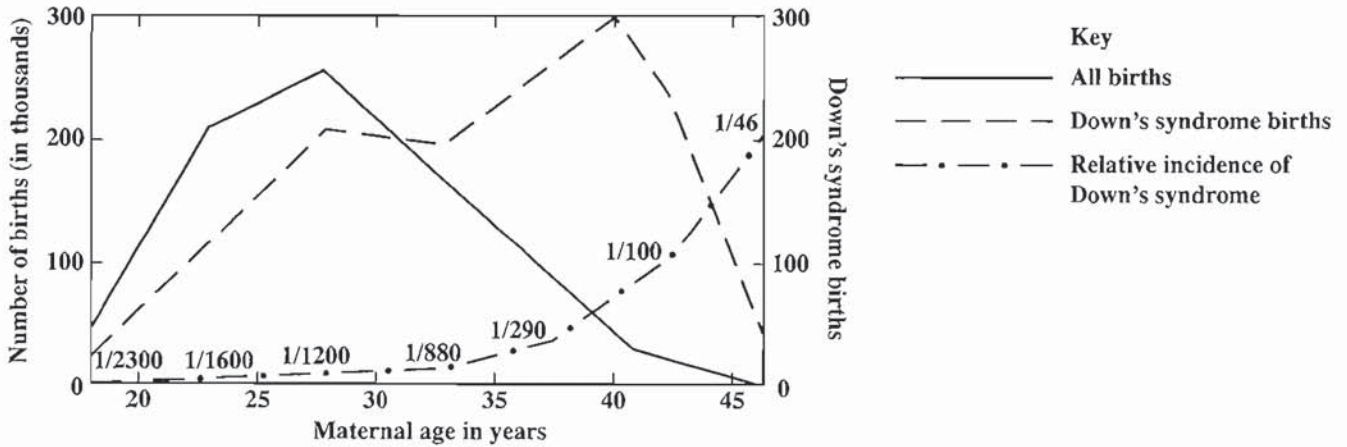

Adapted from: *Heredity and Human Diversity*, S. Tomkins, Cambridge University Press.

Figure 13. Effect of maternal age on incidence of Down's syndrome

- (i) State how Down's syndrome is caused.

[1 mark]

- (ii) With reference to Figure 13, comment on the relative incidence of Down's syndrome with maternal age.

[2 marks]

- (iii) After reaching a peak of around 300, the Down's syndrome birth-rate declines.
Suggest ONE reason for this abrupt decline.

[1 mark]

- (e) How does a gene (point) mutation differ from the type of mutation exemplified in (c) (ii) and (d)?

[1 mark]

Total 10 marks

9. (a) Define the term "natural selection".

[1 mark]

- (b) During the past 50 years, approximately 200 species of insects that attack agricultural crops have become resistant to the pesticide DDT.

Describe how widespread use of DDT could lead to the evolution of resistance in the pests.

[3 marks]

- (c) Each of the following statements describes a process that leads to a specific type of speciation.

Identify the type of speciation indicated in EACH statement.

- (i) Statement 1: This process in nature is most commonly a result of polyploidy.

Type of speciation: _____

[1 mark]

- (ii) Statement 2: This process usually occurs in species that inhabit areas where sharp environmental differences exist.

Type of speciation: _____

[1 mark]

GO ON TO THE NEXT PAGE

- (d) There are many different races of humans, for example, African, European, Indian, Aborigines and Arabs. Although these races are phenotypically different, they belong to one species.

With reference to the biological species concept, explain why humans form a single species.

[1 mark]

- (e) Suggest why speciation is a gradual rather than an instantaneous process.

[3 marks]

Total 10 marks

END OF TEST

The Council has made every effort to trace copyright holders. However, if any have been inadvertently overlooked, or any material has been incorrectly acknowledged, CXC will be pleased to correct this at the earliest opportunity.